

German Army Stabilization Forces

The first German contingent having taken part to the European security and defense common policy (ESDP)-compliant, **EU-led mission in the Democratic Republic of Congo** (DRC) was repatriated, 1 December 2006. Up to that date, these German troops had been integrated into an EU force, whose assigned duty was to secure presidential elections in the DRC and pave the way, through its presence, to a dispassionate and democratic status in this civil-war affected country.

Such commitment from the Bundeswehr was unconceivable fifteen years ago. The whole population and the media would surely have made a fuss about the subject. Now that the Bundeswehr has been regularly stepping in some UN, NATO and EU led missions, stabilization-operations **are now considered a routine or so.**

BY MAJOR (I.G.¹) MATZKEN HEERESAMT I 1 (3)

The political-military situation has been subject to drastic changes since the 90's. Many countries, including Germany, have taken their chance forging a better future for themselves out of a globalizing free-market and improving technology. Quick switches have occurred at the planet-scale and are still rolling on even faster. Climax to the "Eastern Block" collapse, many of its former members have rejoined NATO and the EU. Thus, the past threatening "Cold War" scenario is not likely to reproduce again. The so created **Euro-Atlantic area of stability** seems to preserve our liberty and security **as never seen before in history.**

In return, other types of threat came up nesting in the power-gaps left by this new "world-order", i.e. ethnic and religious conflicts, which got burgeoning together with the international terrorism.

In a "white-book" on the German Defense/Security Policy and the Bundeswehr's future, published in 2006, the Federal Government

establishes the various tasks that its armed forces are going to deal with in response to these new threats that are not only directed at our country, but also at all our allies.

International terrorism; the proliferation of weapons of mass destruction and their vectors; also the many areas of unrest created by States disintegrating therein; all these dangers clearly address measures for the preservation of security. As such, these would require "a truly cooperative and articulate safeguard policy, at the national and the international levels, which could also face risks and threats where they originate²".

Therefore, the Federal Government seeks responses for that 21st century's series of threats, noticeably with a **"Bundeswehr instrumental to the wide-ranging and prospective demarche, which guides our defense and security policy³".** Participation in **stabilization operations** helps reach that goal.

However, what does a **military operation of stabilization** mean precisely? In the newer field-manual for Army forces "Hv 100/100", actually a draft paper named "Combined arms Command for Land Forces", there is a full chapter presenting **stabilization as one of the four combat-procedures currently admitted, besides offense, defense and delaying actions.** The same chapter specifies to future combined arms Commanders that a stabilization mission is meant to **bridle the conflict, compel the warring parties to give up fighting, prevent hostilities from resurging, and establish a secure environment.** Therefore, the combined arms commander is to gain warring parties on compliance or neutralize them if they are not willing to cooperate. He will also work on getting trust and adherence from the population's side⁴. Reversibility of operations and more or less progressive or sudden changes in intensity would characterize such type of operation.

Stabilization operations put a challenge to Bundeswehr⁵

How does the Bundeswehr and, more precisely the German Army, meet the challenge posed by stabilization operations?

In January 2007, the situation can be described as follows. Besides the troops committed to minor operations, Germany is providing about 900 military personnel to EUFOR, 2,400 to KFOR, 2,900 to ISAF and 1,000 to UNIFIL. Additionally, an Operational Reserve Force (ORF) of 650 is kept on stand-by in Germany. A few times ago, one more contingent of 750 troops was participating in an EU-led, stabilization operation in RD Congo.

Troops and units must be especially equipped, educated and trained for such kinds of operations and missions.

Thus, the Bundeswehr has started generating forces with enhanced structural, material and individual capabilities, the latter including psychological preparation to expeditionary operations. Same deep changes affect the German Army, which is the main contributor in stabilization operations with 50% of its strengths - some 7,500 military personnel - regularly ordered into action.

The security context aforementioned, together with quickly evolving political, social, economic, and technological factors, did play as a trigger-background for the whole transformation process.

Within a context of **Bundeswehr's transformation**, that goes together with the one of the German Army, plan is meant to meet that challenge whilst re-assorting current military personnel to **three different categories of forces**, each of them specialized in one type of commitment, namely: **intervention, stabilization and support operations**. These forces will be optimized for the spectrum of tasks they are going to be assigned, with regard to the capabilities demanded and the budget available to get them.

Formations dedicated to **intervention** are mainly designed for high-intensity combat conditions occurring in a "combined-joint", information-centered environment. Conversely, **supporting forces** would primarily **assist the forces oriented to intervention and stabilization missions** in preparing/running operations in Germany and/or a distant theater. **Stabilization forces** are planned for long-lasting employment in **low to medium intensity combat-conditions**, and the larger variety of tasks that stabilization and peace-support operations would demand⁶.

Stabilization forces

Given today's security status in this world of ours, Germany and, by the way, its allies would rather commit itself in stabilization operations. These require a large variety of qualifications from the military, Army troops in particular. Grasp of the cultural, ethnical and social situation of the civil populations present in theater not only facilitates the mission, but it also contributes notably in force protection issues. Indeed, stabilization forces will actually rule the scene under the condition that military means and actions keep visibly commensurate to the mission. As well, full understanding of the situation and its likely evolution is instrumental to supporting the **stabilization process in theater**. In that scope, constant Intelligence-coverage is essential.

Their mission

The primary mission of the stabilization forces is to create the conditions for a durable peace settlement, so that a functional government/social structure can be established. As necessary, these forces may participate in nation-building activities. Should the situation turn worse than expected, these forces should be armed and fit for clashes possibly escalating in high-intensity combats, whichever the level of command is

considered. Therefore, their possible cooperation with intervention forces must be based on a set of concepts and exercises common to both categories of troops. From a military point of view, it can be useful and reasonably envisioned to engage intervention units and stabilization forces simultaneously under a unique Command/HQ, or to order them successively into action at very close times or in areas very close-by. According to basic directions stated forth in the National Defense Policy Book, the whole of the German stabilization forces should be **ready for commitments to a maximum of five separate theaters at the same time**. This would mobilize a resource of 14,000 troops in total.

Stabilisierungsdivisionen

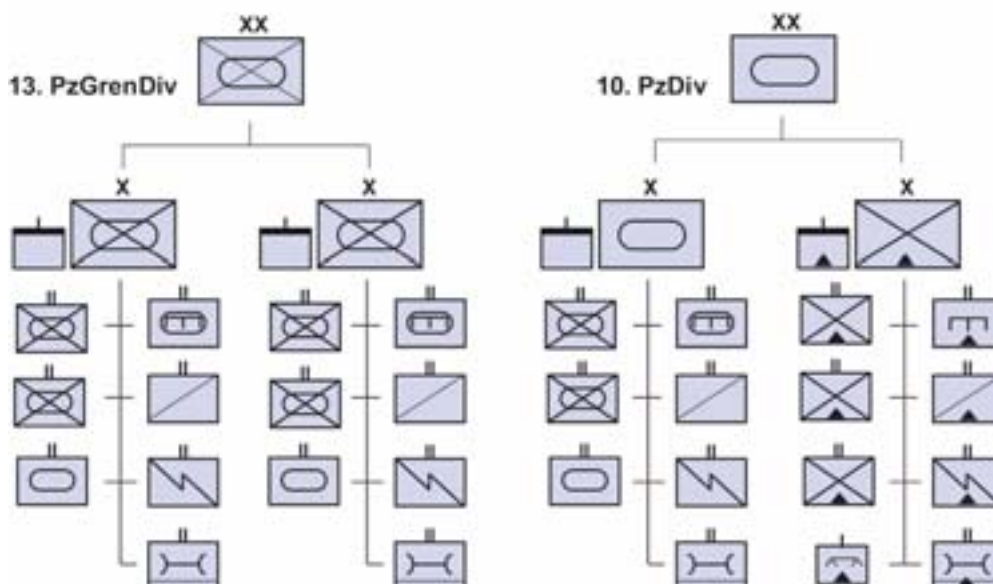

Their structures

German Army stabilization forces are organized in **two divisions**. HQ, **10th Armored Division** and HQ **13th Mechanized Infantry Division** cater for **C2 responsibility over two “stabilization brigades” each**, though these staffs would not necessarily deploy as an OHQ proper. These Div HQs are responsible for their Brigades’ training and preparation to combat.

The **main body of stabilization forces** is made of **three** slightly different, mechanized brigades - two mechanized infantry brigades and one armored brigade - and **one mountain infantry brigade**. Strong with three combat battalions; one Intel battalion; one signal battalion; one engineer battalion and one CSS battalion; these stabilization brigades are ideally structured and equipped for separate, long-lasting missions.

More precisely, each mechanized brigade encompasses two mechanized infantry battalions and one armored battalion, whereas the mountain infantry brigade being composed of three “Alpenjäger” battalions. As such, these stabilization forces are suitably tailored for **combined arms’ styles of action and personnel-demanding military tasks** such as interposition activities, checkpoints handling, and patrolling. Where appropriate, all these forces may be placed under command of the **Framework HQ** that the airmobile division is tasked to deploy for stabilization operations.

The other elements identified as stabilization forces are the 31st airborne brigade detached from the special operations division; the Army, combat-support and logistic Command; also AMB’s modules detached from the airmobile division.

Conversely to the intervention forces, the brigades belonging to the stabilization forces are not organically equipped with field artillery but the combat support and logistic Command can cater for such reinforcement from the airmobile division as necessary.

Stabilization forces preparation

Education and training

Broadly speaking, stabilization forces can only incorporate **professional troops, contracted personnel, and volunteers recruited for a given time** because of the qualifications required for expeditionary operations, which are anyway subject to prior approval by the Bundestag⁸. Same **education and training** apply to intervention and stabilization forces **except in terms of topics priority**, since the latter may also have to deal with high-intensity combat-condition in a limited space/time framework, should the situation command. Nevertheless, all Army personnel are going to share the very **same basic doctrinal approach**. Basic and advanced courses for all military leaders and future commanders are based on similar rules, thus addressing uniformed qualifications and programs.

On the principle, education and training for stabilization forces mainly address low to medium intensity combat-conditions. However, **the ability at high-intensity combats must be maintained** and such sequences will be played, regularly, in all tactical, peace-support mission exercises⁹ applying up to the level of a Combined Arms Battalion Task Force. Consistent with their primary employment-conditions in low to medium intensity operations, stabilization troops will be mainly trained on how to interpose between conflicting parties; ensure that a cease-fire agreement is respected; enforce measures of embargo; respond to local attacks from regular/irregular troops;

protect local authorities; and secure law and order across the assigned theater. Additional education-programs will deal with topics such as information operations superiority and cooperation with international, governmental or non-governmental organizations.

Equipment

Besides education and training, **equipment** is the other key-aspect of **force protection**. The growing number of armored vehicles, possibly hardened, which are deployed in theater, demonstrates serious concerns for security issues during stabilization operations. The German Army seems to have already reached a high level of protection with the **DINGO 2** (armored scout vehicle); the **MUNGO** (Special operations forces tactical vehicle); the **WIESEL 2**, the **Hägglund BV-206-S** (armored personnel carrier); and the **BOXER** (a modular armored vehicle). The Future’s Infantry Combat Suit (French “**FELIN**”-equivalent) will help display improved performances in the fields of combat-superiority, durability, C2 functions, mobility, and the survivability of soldiers dismounted.

Accurate **information on the enemy** also contributes in force protection. Our intelligence network is already equipped with high-performance tools such as the reconnaissance vehicle **FENNEK**, the Artillery radar system **COBRA** and target acquisition drone systems (**KZO BREVEL**, or **LUNA**). The German Army is going to beef up its detection network with the **ALADIN**, a drone operating in the troops’ vicinity-area (within a range



Major MATZKEN

GERMAN LAND FORCES

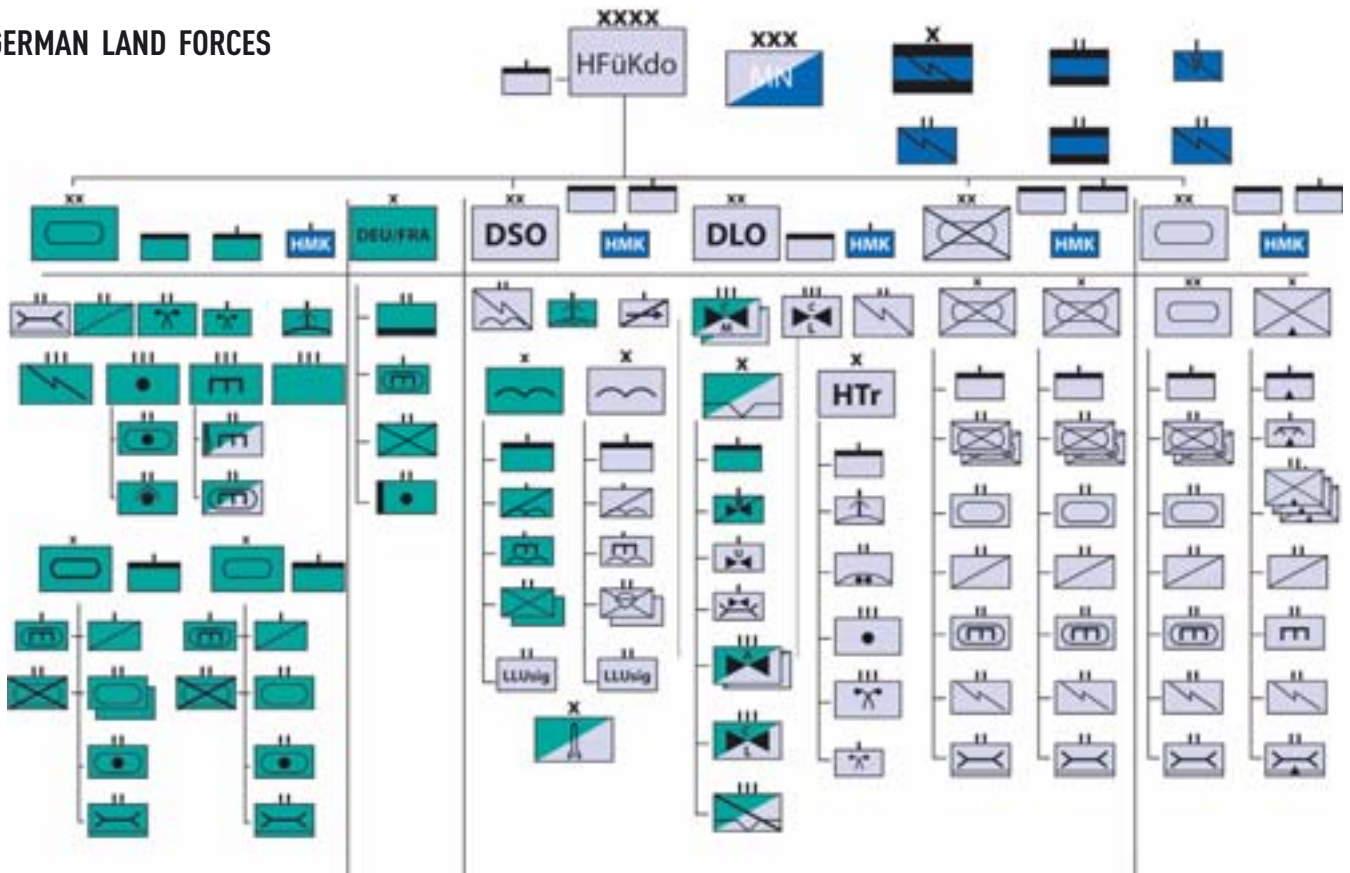

of 5 km or so), and micro-drones dedicated to the surveillance of urban areas.

On the subject of modernization, Army is placing much hope in one of its major R&D project, the armored infantry fighting vehicle PUMA. A real quality-leap in terms of serviceability, this combat vehicle should equip intervention and stabilization forces as well.

Forces, employment planning

Apart from exploratory orientations, financial constraints and pieces of technology available “from the shelves”, the development of newer systems will continue to depend largely on concrete operational requirements, threats identified, and the missions assigned to our troops. On its side, the German Army has established **a detailed rotation plan for its units deployed in current operations, from now on to 2008**, with

account to the transformation process running in parallel. Army’s operational planning for beyond 2009 will be based on strengths provisioned forth in the “New Land Forces” structure and the number of units assorted to each function-related category composing them. Given the number of operations presently running or planned, **the German Army cannot meet all of its operational requirements out of the sole stabilization forces.** This is why its rotation plan for stabilization operations will change by 2009. On a yearly basis, the two divisions allotted to the stabilization forces (10th Armored and 13th Infantry) will assume in turns this responsibility, with the 1st Armored Division normally earmarked for intervention operations which will play the role of “lead division” for the circumstance. The air-mobile and the special operations divisions will support them all.

The **intervention operations branch** will systematically cater for Germany’s commitment to the **NRF** and the **EU BG 1,500**, whilst harnessing its division to them in priority, and units from the stabilization forces providing support assets as appropriate.

1 Graduate, German Army Staff College (Führungsakademie).

2 Livre blanc 2006, p. 8.

3 Livre blanc 2006, p. 11.

4 Draft Field-Manual HDv 100/100, 12007.

5 Intermediate headlines added by the editor.

6 WWH, 2nd update-release, p. 34

7 Quote from the draft, field manual HDv 100/100: combined arms procedures typically apply where national or multinational military assets would interact, at the tactical level, in an operation placed under the responsibility of a unique commander, whose objective’s completion depends on the full spectrum of missions that the land forces can actually achieve, including non-military tasks.

8 FRG’s Parliament.

9 Guideline directive for the “New Army Forces” exercises, chap. 2, p. 3.

Every member of the German Army must be combat-capable and properly utilize his working tools. In that scope, the reorganization in different categories of forces is not going to create 1st class and 2nd class types of unit. We will continue to possess **one Army standing as the pillar instrumental to land operations, placed under a unique command, and governed by the same united and cooperative military policy and culture.**